

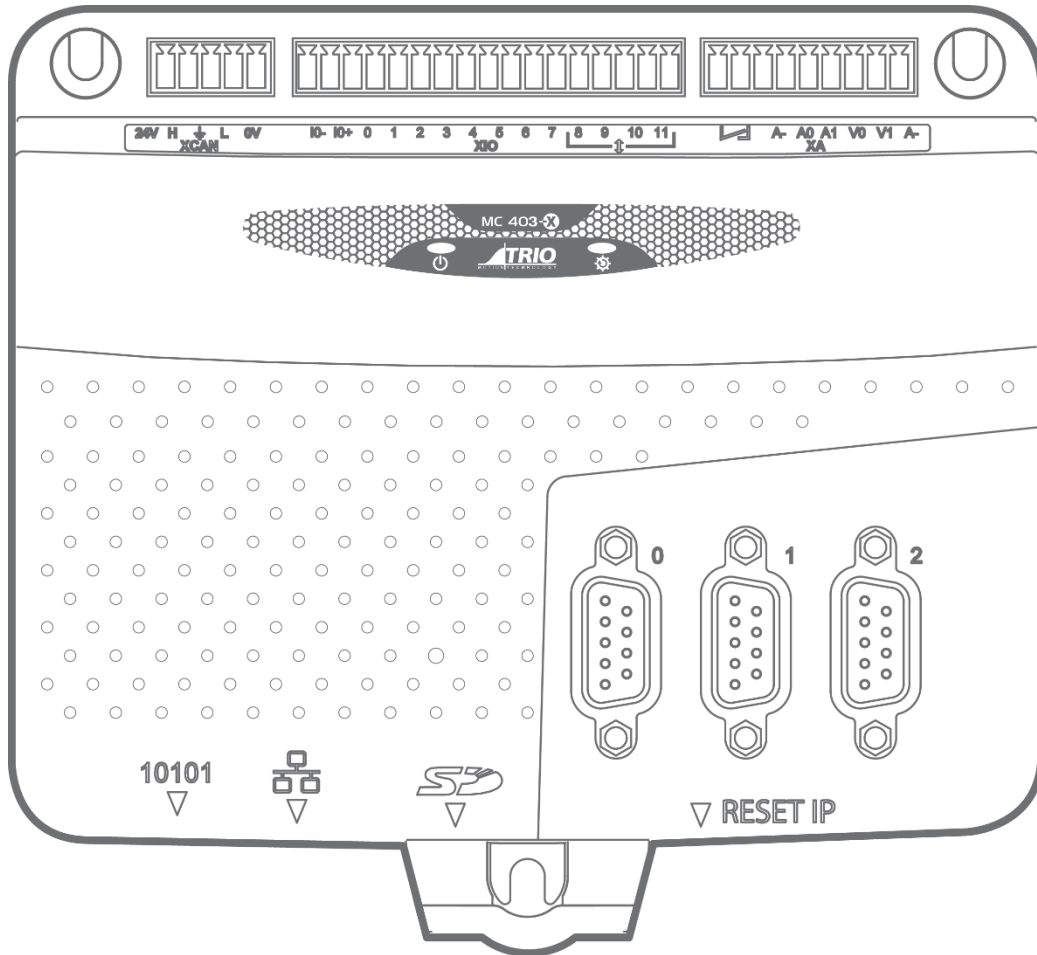

A MEMBER OF THE **ESTUN** GROUP



MC403-X

3 AXIS MOTION COORDINATOR

USER MANUAL

About this Manual

Purpose

This manual provides the information required for the Selection, Wiring, Connection, Setup, Operation and Functions of the MC403-X Motion Coordinator.

Please read and understand this manual to ensure correct usage of the product.

Terms

Terms that may be used in this manual are defined as follows.

Term	Meaning
Axis	A software control that operates a Servo or Stepper Motor.
Drive	A Servo or Stepper Drive, which is used for controlling the Motor.
Servo System	A Servo Control System that includes a Motor, a Drive, a host controller (Motion Coordinator) and peripheral devices.
WDOG ON	Closing a solid-state relay to signal that the Drives may be Enabled.
WDOG OFF	Open the solid-state relay to signal that the Drives must be Disabled.
Motion Perfect	The PC Tool for commissioning and programming the Trio product suite.
Pulse+Direction	An electronic output from the Motion Coordinator that produces one pulse per step of the motor position, with a second output to signal the direction of motion.
Analogue Servo	+/- 10v output to give speed signal to the servo drive. Associated encoder input provides position feedback

Revision History

Date	Version	Revised Contents
20 Dec 2022	1.00	First Release

All goods supplied by Trio are subject to Trio's standard terms and conditions of sale.
This manual applies to systems based on the Motion Coordinator MC403.

The material in this manual is subject to change without notice. Despite every effort, in a manual of this scope errors and omissions may occur. Therefore, Trio Motion Technology Ltd. cannot be held responsible for any malfunctions or loss of data as a result.

Copyright (C) 2022-23 Trio Motion Technology Ltd.
All Rights Reserved

UK

Trio Motion Technology Ltd.
Phone: +44 (0)1684 292333

USA

Trio Motion Technology LLC.
Phone: + 1 724 472 4100

CHINA

Trio Shanghai
Tel: +86 21 587 976 59

INDIA

Trio India
Phone: +91 827 506 5446

Safety Warning



During the installation or use of a control system, users of Trio products must ensure there is no possibility of injury to any person, or damage to machinery.

Control systems, especially during installation, can malfunction or behave unexpectedly.

Users must ensure that in all cases of normal operation, controller malfunction, or unexpected behaviour, the safety of operators, programmers or any other person is totally ensured.

Contents

Revision History	2
User Manual MC403-X.....	6
Overview	6
Programming.....	6
I/O Capability.....	6
Communications.....	6
Removable storage.....	7
AXIS POSITIONING FUNCTIONS.....	7
CONNECTIONS TO THE MC403 ETHERNET PORT CONNECTION	8
MC403-X SERIAL CONNECTIONS.....	8
SERIAL CONNECTOR.....	9
MC403-X PULSE OUTPUTS / ENCODER INPUTS	9
REGISTRATION	10
5-WAY CONNECTOR	10
I/O CONNECTOR 1.....	11
24V INPUT CHANNELS	11
I/O POWER INPUTS	11
24V I/O CHANNELS	11
I/O CONNECTOR 2.....	12
AMPLIFIER ENABLE (WATCHDOG) RELAY OUTPUTS	12
ANALOGUE INPUTS	12
ANALOGUE OUTPUTS.....	12
LED DISPLAY.....	13
MC403-X FEATURE SUMMARY	14
MC403-X AXIS CONFIGURATION SUMMARY	15
CONFIGURATION KEY	15
CORE FUNCTIONALITY	15
EXTENDED FUNCTIONALITY	16

User Manual MC403-X

Overview

The Motion Coordinator MC403-X uses high performance Cortex M7 Processor with 3 flexible Axis ports. Provides 2 axes of servo plus a master encoder axis, or 3 axes of pulse+direction control for stepper drives or pulseinput servo drives. Trio uses advanced FPGA techniques to reduce the size and fit the pulse output and servo circuitry in a compact DIN-rail mounted package. The MC403-X is housed in a rugged plastic case with integrated earth chassis and incorporates all the isolation circuitry necessary for direct connection to external equipment in an industrial environment. Filtered power supplies are included so that it can be powered from the 24V d.c. logic supply present in most industrial cabinets. It is designed to be configured and programmed for the application using a PC running Trio's Motion Perfect application software, and then may be set to run "standalone" if an external computer is not required for the final system. Programs and data are stored directly to Flash memory, thus eliminating the need for battery backed storage. The Multi-tasking version of Motion-iX for the MC403-X allows up to 6 Motion-iX programs to be run simultaneously on the controller using pre-emptive multi-tasking. In addition, the operating system software includes the IEC 61131-3 standard run-time environment (licence key required).



Programming

The Multi-tasking ability of the MC403-X allows parts of a complex application to be developed, tested and run independently, although the tasks can share data and motion control hardware. The 6 available tasks can be used for Motion-iX or IEC 61131-3 programs, or a combination of both can be run at the same time, thus allowing the programmer to select the best features of each.

I/O Capability

The MC403-X has 8 built in 24V inputs and 4 bi-directional I/O channels. These may be used for system interaction or may be defined to be used by the controller for end of travel limits, registration, datuming and feedhold functions if required. The MC403-X can have up to 512 external Input and Output channels connected using DIN rail mounted CAN I/O modules. These units connect to the built-in CANbus port.

Communications

A 100 base-T Ethernet port is fitted as standard and this is the primary communications connection to the MC403-X. Many protocols are supported including Telnet, Modbus TCP, Ethernet IP and TrioPCMotion. Check the Trio website (www.triomotion.com) for a complete list.

The MC403-X has one built in RS232 port and one built in duplex RS485 channel for simple factory communication systems. Either the RS232 port or the RS485 port may be configured to run the Modbus or Hostlink protocol for PLC or HMI interfacing.

If the built-in CAN channel is not used for connecting I/O modules, it may optionally be used for CAN communications. E.g. DeviceNet, CANopen etc.

Removable storage

The MC403-X has a micro-SD Card slot which allows a simple means of transferring programs, firmware and data without a PC connection. Offering the OEM easy machine replication and servicing.

The memory slot is compatible with a wide range of micro-SD cards up to 32Gbytes using the FAT32 compatible file system.



AXIS POSITIONING FUNCTIONS

The motion control software receives instructions to move an axis or axes from the Motion-iX or IEC 61131-3 language which is running concurrently on the same processor. The motion generation software provides control during operation to ensure smooth, coordinated movements with the velocity profiled as specified by the controlling program. Linear interpolation may be performed on groups of axes, and circular, helical or spherical interpolation in any two/three orthogonal axes. Each axis may run independently or they may be linked in any combination using interpolation, CAM profile or the electronic gearbox facilities.

Consecutive movements may be merged to produce continuous path motion and the user may program the motion using programmable units of measurement (e.g. mm, inches, revs etc.). The module may also be programmed to control only the axis speed. The positioner checks the status of end of travel limit switches which can be used to cancel moves in progress and alter program execution.

CONNECTIONS TO THE MC403 ETHERNET PORT CONNECTION

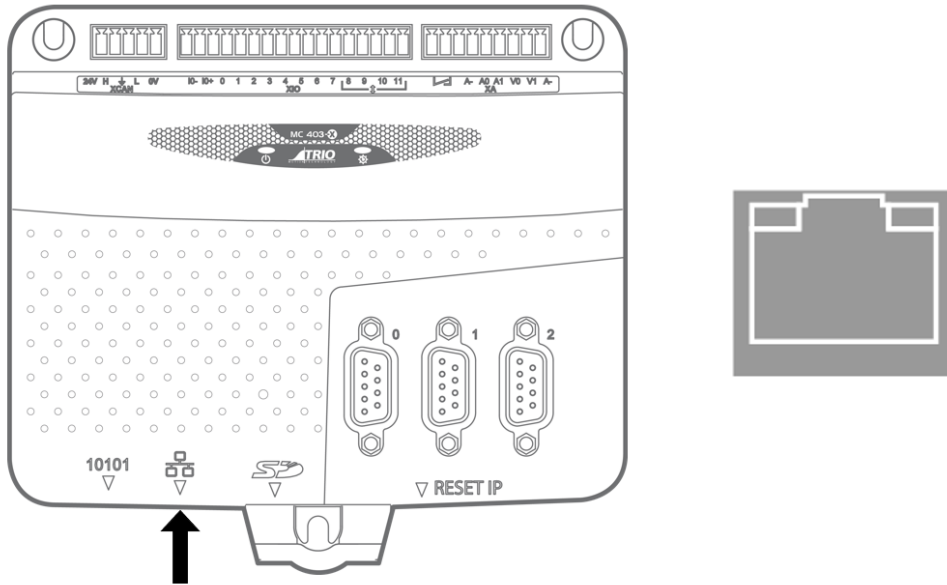

Physical layer: 100 base_T

Connector: RJ45

The Ethernet port is the default connection between the Motion Coordinator and the host PC running the Motion Perfect development application.

To reset the IP _ ADDRESS, IP _ GATEWAY and IP _ NETMASK to their default values press the IP reset button and power cycle the controller while keeping the button pressed.

MC403-X SERIAL CONNECTIONS

The MC403-X features two serial ports. Both ports are accessed through a single 8 pin connector.

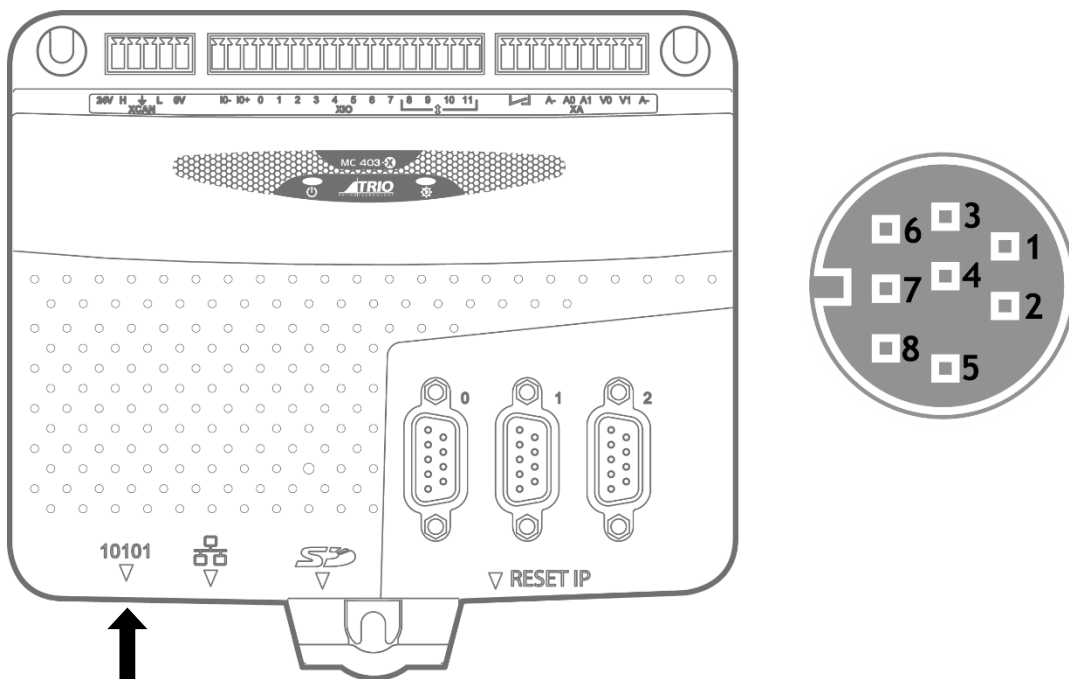

SERIAL CONNECTOR

Pin	Function	Note
1	RS485 Data In A Rx+	Serial Port #2
2	RS485 Data In B Rx-	
3	RS232 Transmit	Serial port #1
4	0V Serial	
5	RS232 Receive	Serial port #1
6	Internal 5V	5V supply is limited to 150mA, shared with sync port
7	RS485 Data Out Z Tx-	Serial port #2
8	RS485 Data Out Y Tx+	Serial port #2

MC403-X PULSE OUTPUTS / ENCODER INPUTS

The MC403-X is designed to support any combination of servo and pulse input motor drives on the standard controller hardware. The MC403-X has 3 versions, which are selected by applying Feature Enable Codes (FECs)

- 1) 2 axis as either encoder or pulse output. (P865)
- 2) 1 axis servo with the other 2 axis as either encoder or pulse output. (P866)
- 3) 2 axis servo and the other axis as either encoder or pulse output. (P867)

The axis configuration can then be set with the axis ATYPE parameter.

The function of the 9-pin ‘D’ connectors will be dependent on the specific axis configuration which has been defined. If the axis is setup as a servo or encoder, the connector will provide the encoder input. If the axis is configured as a pulse+direction, the connector provides differential outputs for step/direction and enable signals. The encoder port also provides a current-limited 5V output capable of powering most encoders. This simplifies wiring and eliminates external power supplies.

- (1) Servo, encoder and stepper versions of the MC403-X

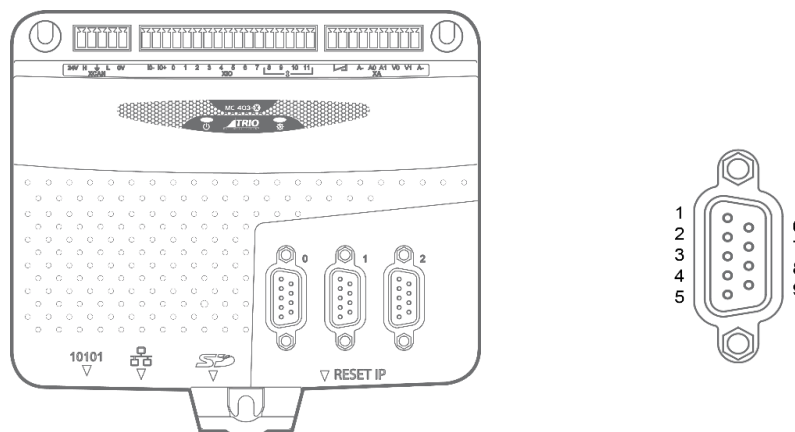

Pin	Function	Pulse and Direction	Absolute Encoder
1	ENC. A	Step+	Clock+
2	ENC. /A	Step-	Clock-
3	ENC. B	Direction+	N/C
4	ENC. /B	Direction-	N/C
5	0V Encoder	OV Pulse+direction	0V Encoder
6	ENC. Z	Enable+	Data+
7	ENC. /Z	Enable-	Data-
8	5V *	5V *	5V *
9	N/C	N/C	N/C

*5V supply is limited to 150mA (shared with serial port)

REGISTRATION

Each MC403-X encoder port has 2 available registration events. These are assigned in a flexible way using REG_INPUTS to any of the 8 digital inputs or can be used with the Z mark input on the encoder port.

5-WAY CONNECTOR

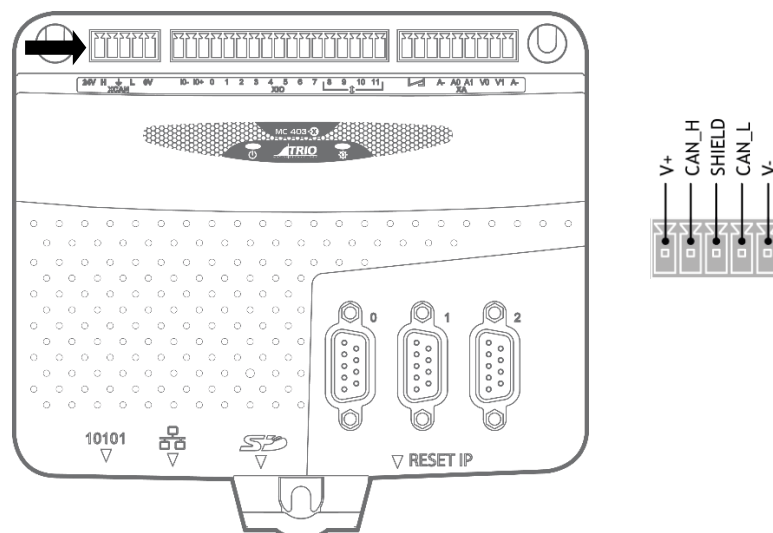

This is a 5 way 3.5 mm pitch connector. The connector is used both to provide the 24 Volt power to the MC403-X and provide connections for I/O expansion via Trio’s digital and analogue CAN I/O expanders. 24 Volts must be provided as this powers the unit.

This 24 Volt input is internally isolated from the I/O 24 Volts and the +/-10V Voltage outputs.



24V d.c., Class 2 transformer or power source required for UL compliance. The MC403-X is grounded via the metal chassis. It **MUST** be installed on an unpainted metal plate or DIN rail which is connected to earth. An earth screw is also provided on the rear of the chassis for bonding the MC403-X to ground.

I/O CONNECTOR 1

24V INPUT CHANNELS

The MC403-X has 8 dedicated 24V Input channels built into the master unit. A further 256 inputs can be provided by the addition of CAN I/O modules. The dedicated input channels are labelled channels 0..7. Inputs 0 to 7 can be used as high speed registration inputs for axes 0 to 2, using the REGIST command.

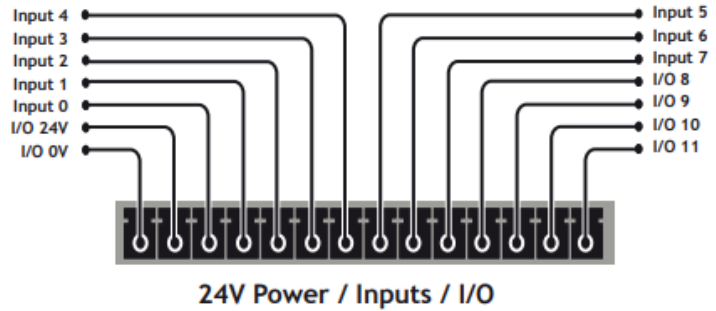

I/O POWER INPUTS

The I/O 0 Volts (IO-) and I/O 24 Volts (IO+) are used to power the 24 Volt digital IO and the analogue I/O, including the servo DAC outputs. The digital I/O connections are isolated from the module power inputs. The analogue inputs and outputs are isolated from the digital I/O and the module power inputs.

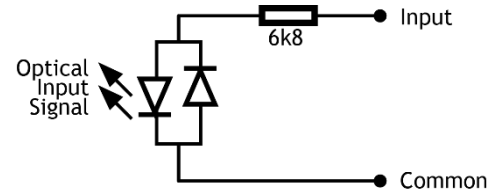

24V I/O CHANNELS

Input/output channels 8..11 are bi-directional. The inputs have a protected 24V sourcing output connected to the same pin. If the output is unused it may be used as an input in the program. The input circuitry is the same as on the dedicated inputs. The output circuit has electronic over-current protection and thermal protection which shuts the output down when the current exceeds 250mA.

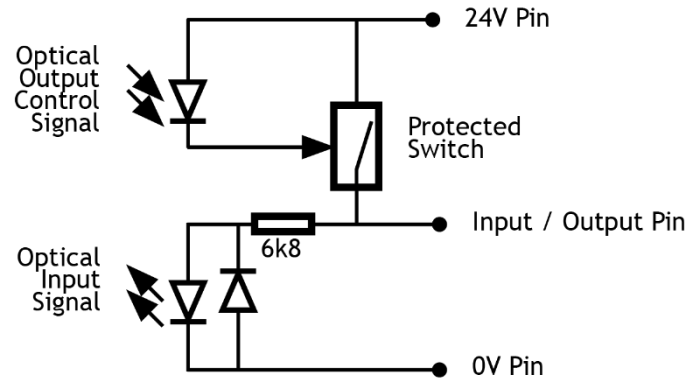

Care should be taken to ensure that the 250mA limit for each output circuit is not exceeded, and that the total load for the group of 4 outputs does not exceed 1 amp.

I/O CONNECTOR 2

AMPLIFIER ENABLE (WATCHDOG) RELAY OUTPUTS

An internal relay contact is available to enable external amplifiers when the controller has powered up correctly and the system and application software is ready. The amplifier enable is a solid-state relay with an ON resistance of 25Ω at 100mA. The enable relay will be open circuit if there is no power on the controller OR a motion error exists on a servo axis OR the user program sets it open with the WDOG=OFF command.

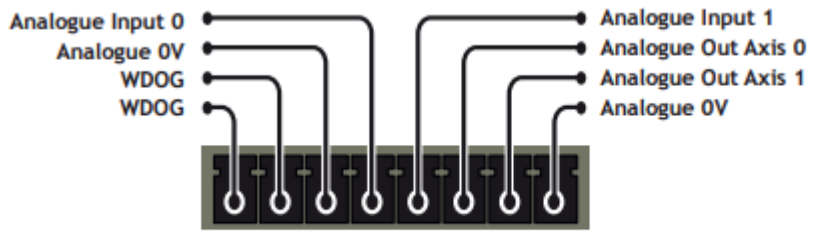

WDOG / Analogue Inputs / Outputs

The amplifier enable relay may, for example, be incorporated within a hold-up circuit or chain that must be intact before a 3-phase power input is made live.



 All stepper and servo amplifiers must be inhibited when the amplifier enable output is open circuit

ANALOGUE INPUTS

Two built-in 12 bit analogue inputs are provided which are set up with a scale of 0 to 10V. External connection to these inputs is via the 2-part terminal strip I/O connector 2. A 24V d.c. supply must be applied to I/O connector 1 to provide power for the analogue input circuit.

ANALOGUE OUTPUTS

The MC403-X has 2 12-bit analogue outputs scaled at +/-10V. Each output is assigned to one servo axis, or in the case where the axis is not used, or is set as a

pulse+direction/simulated encoder output, the analogue output may be set to a voltage directly in software, using the DAC parameter

A 24V d.c. supply must be applied to I/O connector 1 to provide power for the analogue output circuit.

LED DISPLAY

On power-up, the LEDs flash to show the MC403-X version and the SD card status.

P865 2 axis pulse output version:	3 flashes of the RED LED.
P866 1 axis servo version:	3 flashes of the GREEN LED.
P867 2 axis servo version:	3 flashes of both LEDs alternately.
SD card loading system software:	Both LEDs flash together until the system SW load is completed.

During operation, the two LED's show the processor (OK) and system status.

Display at start up

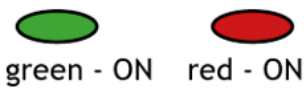

Display with WDOG on

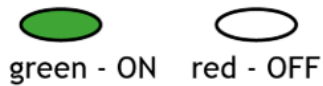

Display Axis Error



MC403-X FEATURE SUMMARY

Dimensions	122 mm x 135 mm x 35 mm (HxWxD).
Weight	346g
Operating Temp.	0 - 45 degrees C.
Control Inputs	Forward Limit, Reverse Limit, Datum Input, Feedhold Input.
Communication Ports	RS232 channel: up to 128k baud. RS485 channel: up to 128k baud. CANbus port (DeviceNet and CANopen compatible). Ethernet: 100 BaseT multiple port connection.
Position Resolution	64 bit position count.
Speed Resolution	32 bits. Speed may be changed at any time. Moves may be merged.
Servo Cycle	125µs minimum, 1ms default, 4ms max.
Programming	Multi-tasking TrioBASIC system and IEC 61131-3 programming system. Maximum 6 user processes.
Interpolation modes	Linear 1-3 axes, circular, helical, spherical, CAM Profiles, speed control, electronic gearboxes.
Memory	8 Mbyte user memory. 512,000 x 64 bit TABLE memory. Automatic flash EPROM program and data storage.
VR	4096 global VR data in FLASH memory (automatic-store).
SD Card	Standard micro-SD Card compatible to 32Gbytes. Used for storing programs and/or data.
Power Input	24V d.c., Class 2 transformer or power source required. 18..29V d.c. at 300mA + IO supply.
Amplifier Enable Output	Normally open solid-state relay rated 24V ac/dc nominal. Max load 100mA. Max Voltage 29V.
Analogue Inputs	2 isolated, 12 bit, 0 to 10V.
Serial / Encoder Power Output	5V at 150mA. (Max)
Analogue Outputs	2 isolated 12 bit, +/- 10V
Digital Inputs	8 Opto-isolated 24V inputs.
Digital I/O	4 Opto-isolated 24V outputs. Current sourcing (PNP) 250 mA. (max. 1A per bank of 4).
Product Codes	P865 : MC403-X 2 axis stepper output / 2 encoder input P866 : MC403-X 1 axis servo + 2 encoder / 2 axis stepper P867 : MC403-X 2 axis servo + 1 encoder / 3 axis stepper

MC403-X AXIS CONFIGURATION SUMMARY

CONFIGURATION	P867	P866	P865
AXIS 0	Extended+AS	Extended+AS*	Extended
AXIS 1	Extended+AS	Extended*	Extended
AXIS 2	Extended	Extended	
AXES			
# of axes (max)	3	3	2
# of virtual axes (max)	16	16	16
DRIVE INTERFACES			
Stepper (Step & Direction)	Yes	Yes	Yes
Servo ($\pm 10V$ & Encoder)	Yes	Yes	No
ENCODER PORTS			
Feedback input	Yes	Yes	Yes
Reference input	Yes	Yes	Yes
Pulse + direction output	Yes	Yes	Yes
Incremental (A+B) output	Yes	Yes	Yes
BUILT-IN I/O			
Inputs 24Vdc	8	8	8
Bi-directional I/O 24Vdc	4	4	4
0-10V analogue inputs	2x12bit	2x12bit	2x12bit
$\pm 10V$ analogue outputs	2x12bit	2x12bit	2x12bit
# registration inputs	6	6	6
Registration input speed	20 μ s max	20 μ s max	20 μ s max

*For P866 - One Axis only can be configured as servo (AS), when Axis 0 is configured as Extended, Axis 1 can be configured as servo (AS), Vice Versa.

CONFIGURATION KEY

CORE FUNCTIONALITY

CORE AXES - can be configured in software as pulse and direction outputs with stepper or servo drives. They can also be configured for incremental encoder feedback.

Core functionality is a set of ATYPES (Axis TYPES) that are available on all controllers. They are based on pulse outputs and incremental encoder feedback.

ATYPE	Description
43	Pulse and direction output with enable output
45	Quadrature encoder output with enable output
63	Pulse and direction output with Z input
64	Quadrature encoder output with Z input Trio Motion Technology HARDWARE OVERVIEW Motion Coordinator MC403 2-54
76	Incremental encoder with Z input
78	Pulse and direction with VFF_GAIN and enable output 1
84	Quadrature encoder output with VFF_GAIN and enable output

EXTENDED FUNCTIONALITY

EXTENDED AXES - in addition to the Core functionality these axes can also be configured for absolute encoders and closed loop servos (requires voltage output).

ANALOGUE SERVO - Only axes marked as AS can use the analogue output for closed loop control.

All Extended Axes can use these ATYPE's as feedback.

If you want to just use the feedback and not complete a closed loop servo system set SERVO = OFF

ATYPE	Description
30	Analogue feedback Servo
44	Incremental encoder Servo with Z input
46	Tamagawa absolute Servo
47	Endat absolute Servo
48	SSI absolute Servo
60	Pulse and direction feedback Servo with Z input
77	Incremental encoder Servo with enable output
79	Pulse and direction feedback with Z input
86	Tamagawa absolute encoder input
87	Endat absolute encoder input
88	SSI absolute encoder input
92	Analogue Servo with Biss absolute encoder
93	Biss absolute encoder input
35	Pulse and direction output with PWM output
36	Incremental encoder Servo with PWM output